

## Quadraphonic Amplifier

### Description:

This is a four channel amplifier ideally suited for use with quadraphonic equipment such as a Sound Blaster Live card. There is no volume control, audio levels being directly controlled from the sound card itself.

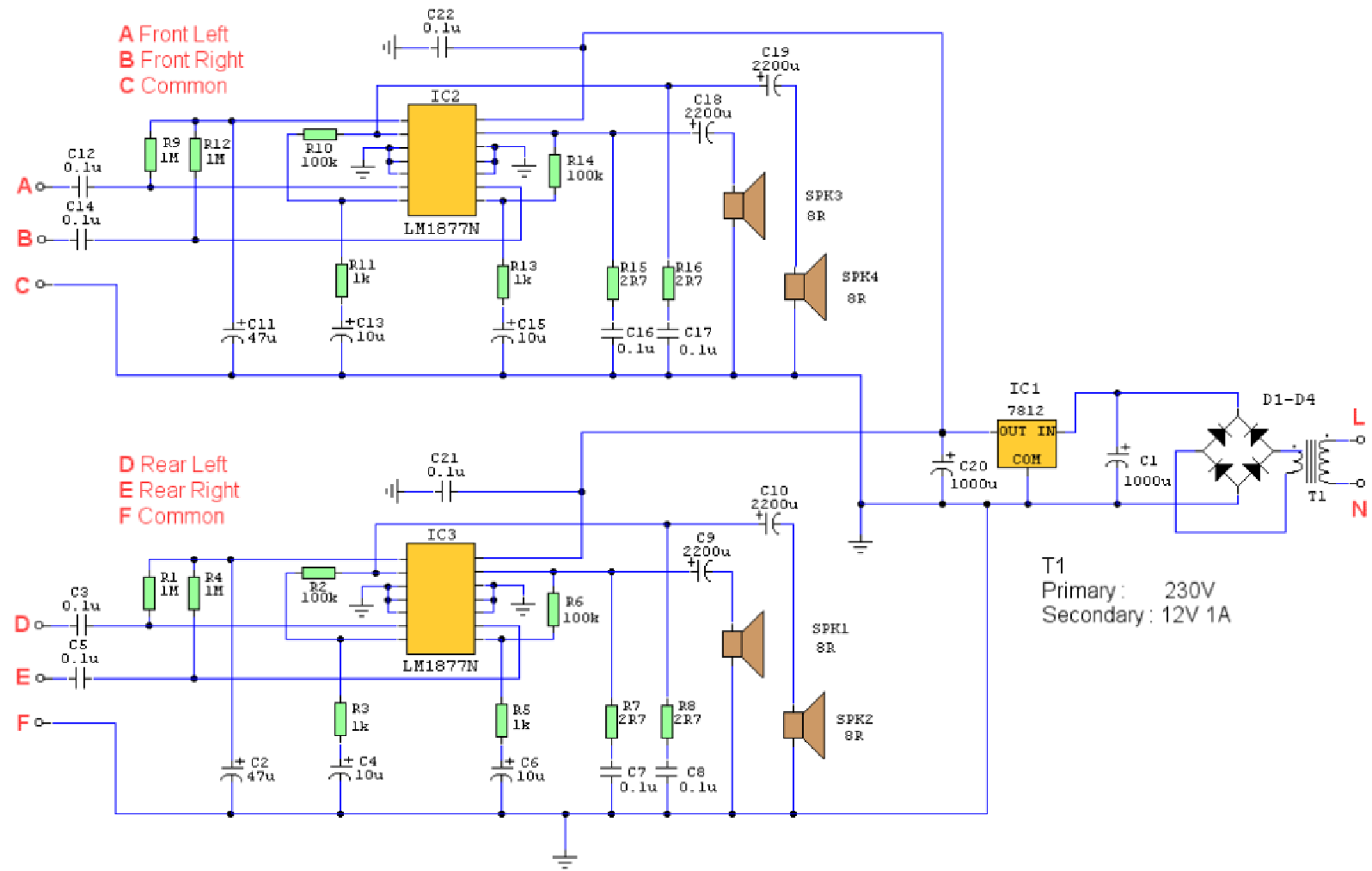

**Parts List:**

D1-D4: 1N4001 (4)

C1,C20: 1000u CAP (2)  
C2,C11: 47u CAP (2)  
C3,C5,C7,C8,C12,C14,C16,C17,C21,C22: 0.1u CAP (10)  
C4,C6,C13,C15: 10u CAP (4)  
C9,C10,C18,C19: 2200u CAP (4)  
R1,R4,R9,R12: 1M RESISTOR (4)  
R2,R6,R10,R14: 100k RESISTOR (4)  
R3,R5,R11,R13: 1k RESISTOR (4)  
R7,R8,R15,R16: 2R7 RESISTOR (4)  
IC1: 7812 (1)  
IC2,IC3: LM1778N (2)  
SPK1,SPK2,SPK3,SPK4: 8R 2 Watt speakers (4)

### Notes:

Construction is straight forward and is suitable for Verobaord. Overall gain is controlled by the ratio  $R14/R13$  and  $R6/R5$ . Used with small hifi speakers the volume was too loud for my room so I reduced  $R14$  and  $R6$  to 33k. The zobel network formed by  $R7,C7,R8,C8,R15,C16,R16,C17$  prevents instability which can happen with long speaker wires. The input impedance is high, 1M and if very long input cables are present could pick up noise. Screened cable should be used, in my case I used 10k resistors between points A & C, B & C, D & F, E & F. This provides a DC path to ground and higher noise immunity. If instability does occur, then you will notice sound distortion and the LM1877N will become hot to touch.

### Connections:

The back of a sound blaster live card has colour coded 3.5mm stereo jacks. The image below shows a close up of the rear of my Sound Blaster Live card. As well as colour coding, each connector has an appropriate marking, for easy connectivity.



The normal output connector is green and the rear speaker connector is black. Creative provide utilities and sound mixer for use with Windows. Under Linux the utility [Gamix](#) can be used, which allows independent volume control for all channels.

Return to [Audio Circuits](#)