

One Watt Audio ~Amplifier~

...with the TAA 300 Integrated Circuit

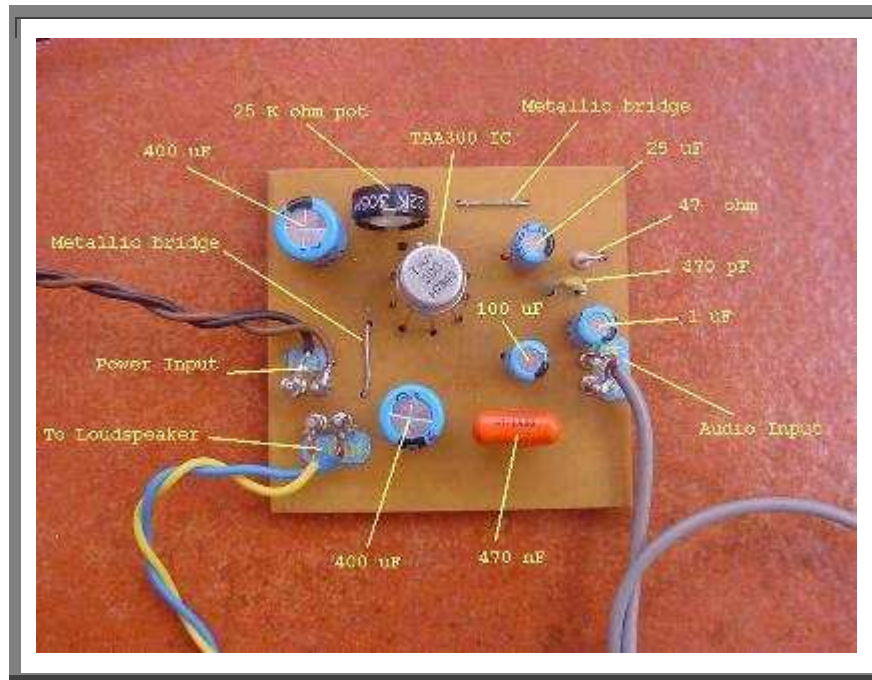

Click [HERE](#) for a larger and more detailed view

I built this audio amplifier with the TAA 300 Integrated Circuit (IC) to have on the work bench an independent amplifier to test audio signals coming from radio receivers or audio oscillators. It is an excellent amplifier to drive an eight ohm loudspeaker. You can use it, for example, as an audio amplifier for the FM one transistor receiver known as the Radio Shack Special and/or the TDA 7000 FM receiver; also to test the workings of a pulse oscillator or any other kind of audio oscillators.

[Schematic Diagram of the One Watt Audio Amplifier](#)

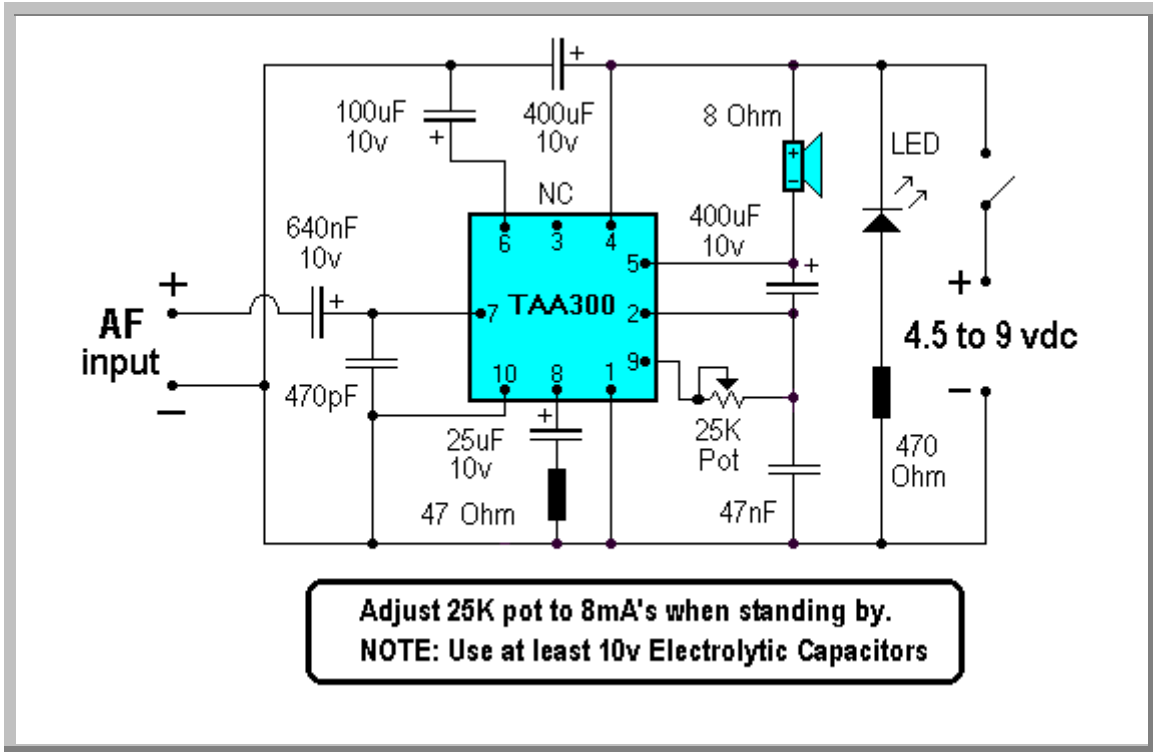

The TAA 300 is a high gain amplifier in which current and power consumption are so low that you can feed it with batteries...from 4.5 to 9.0 volts. This IC is designed to be used in radio and TV receivers, as well as with phonographs and small size high-fidelity systems. With its' maximum one watt of power, you have enough sound to listen confortably to your preferred music in your sitting room. With this audio amplifier, you get one watt of power, which is double the power you get from the common LM 386 IC.

(A picture is also provided of the PCB and components used in the project)

CAPACITORS	RESISTORS	INTEGRATED CIRCUITS (IC)
1* - 0.64uF/15v	1 - 47 ohm (1/2 Watt)	1 - TAA 300 Audio Amplifier
1 - 470pF/ceramic	1 - 25K (Adjustable)	
1 - 25uF/15v		
1 - 47nF/ceramic		
2 - 470uF/15v		

1 - 100uF/15v		
---------------	--	--

***If you have difficulties in finding the 0.64uF capacitor, a 1uF electrolytic/15v will solve the problem.**

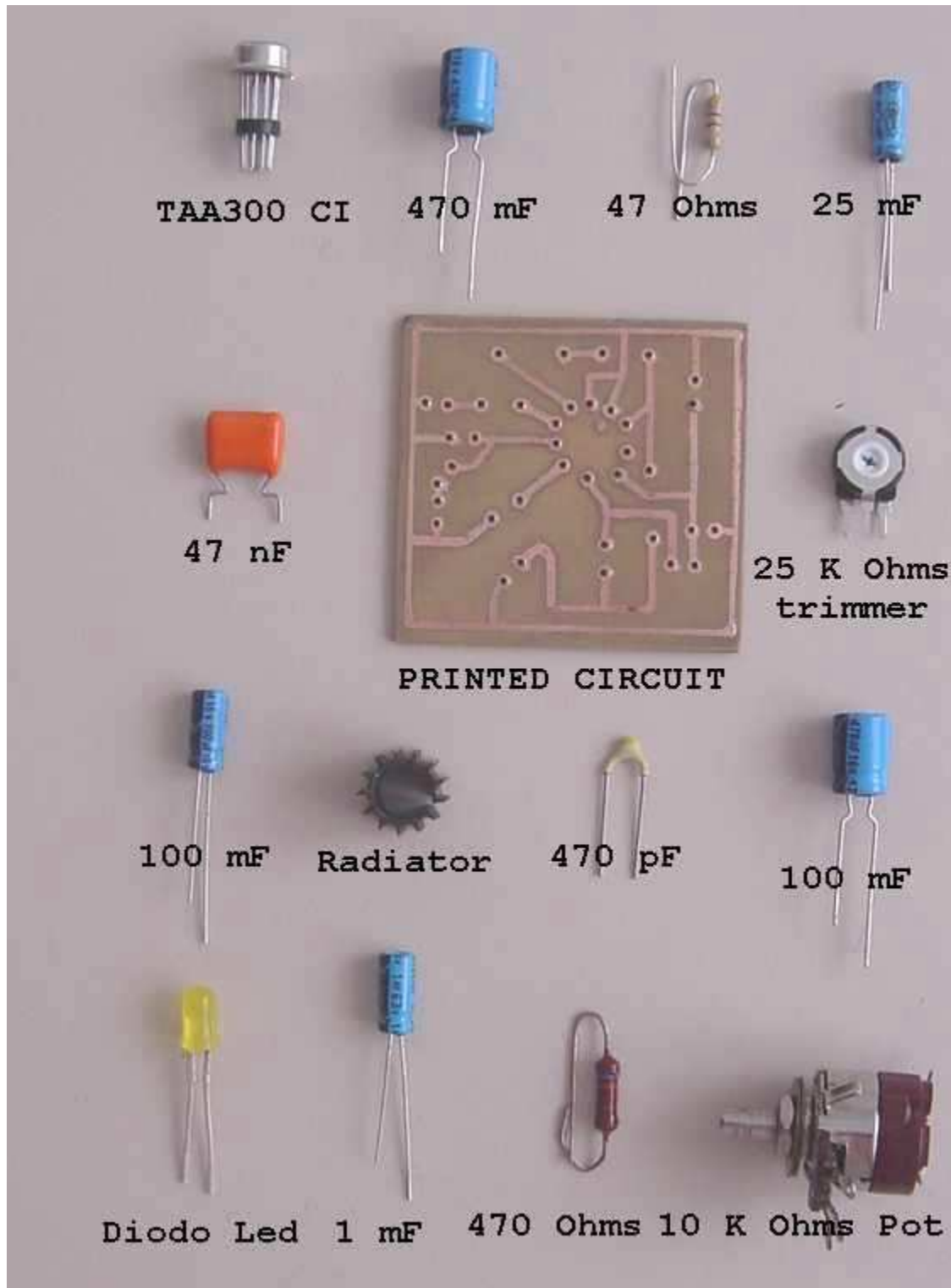

Other components that you can add would be a LED, with a 470 ohm resistor to control the ON/OFF state of the amplifier; a switch (SPST), and an 8 ohm

loudspeaker. Also, the IN and OUT connectors and a plastic, metal or wooden cabinet to suite your taste of enclosure. To nicely finish the project, a potentiometer of 10K connected between the INPUT of the 0.64uF capacitor (that goes to PIN #7), will allow you to regulate the volume of the amplifier to your desired level.

With all the components on the work bench, I started drawing a printed circuit. This printed circuit is not mandatory; you can mount the amplifier in the style you like most. If you decide to use a printed circuit, you can trace it in whatever arrangement you prefer, this is, in accordance with your layout of the components.

I drew my printed circuit on a piece of copper board of 45mm X 47mm with a water-resistant marker..by hand. After taking it from the ferric chloride bath, I found that the result was quite acceptable. The tracts of approximately 1.5mm are wide enough for the small currents that run in the circuit. The current is only a few mA.

Drilling the holes for the component terminals is not difficult at all. After having the printed board finished, we have to be very careful in placing the electrolytic capacitors with its' correct polarities and take special care not to insert the pins of the TAA 300 the wrong way!

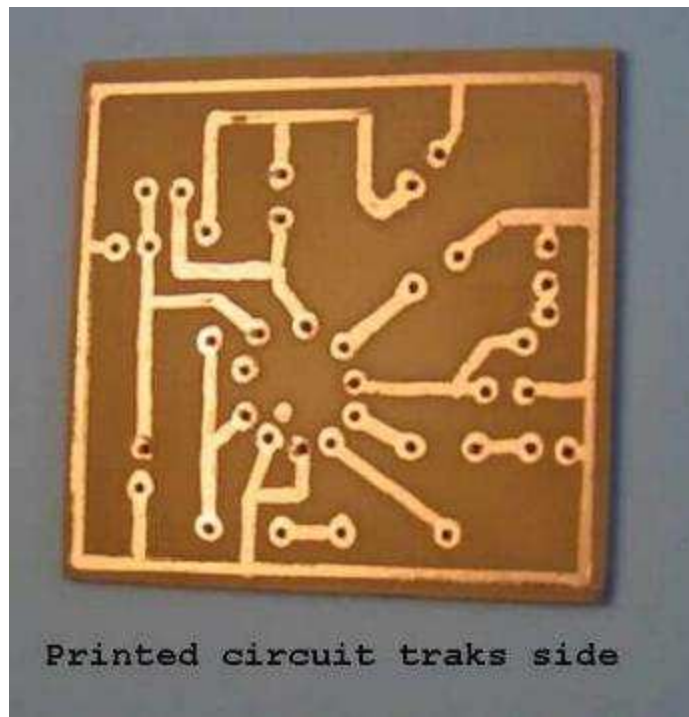

When you buy the TAA 300 IC, get from the employee a clear explanation of the pins position in the capsule of this integrated circuit. It is quite important that you understand where PIN #1 is located on the chip...and also the rest of the pins.

Aside from the identification of the IC pins and the right placing of the electrolytic capacitors, the construction of this audio amplifier would be a pleasure to make...offering no difficult areas.

When finishing and testing, your TAA 300 audio amplifier...if you try it with batteries...be sure that they are fresh batteries. If the batteries are low, their internal resistance will make the circuit malfunction or not work at all.

WARNING

Be careful that the quiescent current of this amplifier in the 'standby' position (without any audio input) be of 8 milli-amperes. An excessive current will overheat the TAA 300 IC. In all cases...USE A HEAT SINK!

Finally, remember that the amplifier works from 4.5 to 9.0 vdc. With 4.5 or 6.0 volts, the circuit works quite well. If you use 9.0 volts to feed the amplifier, it is mandatory that you use a radiator (heat-sink) on the capsule of the IC.